



## P.A. - S.p.A. - EQUIPAGGIAMENTI TECNICI DEL LAVAGGIO

VIA MILANO, 13 - CASELLA POSTALE 115 - 42048 RUBIERA (REGGIO EMILIA) - ITALY  
 Tel. +39 0522 623611 - Fax. +39 0522 629600 - R.E.A. RE 156319 - R. I. RE 11535 - Mecc. RE 013446  
 C.F. e P. IVA 01035950359 - Cap. Soc. i.v. € 750.000,00 - Codice Identificativo C.E.E. IT 01035950359  
 ART. 2497 - BIS C.C. DIREZIONE E COORDINAMENTO BENETTI srl R.I. TRIB. DI RE 01480690351  
<http://www.pa-etl.it> - E-mail: [info@pa-etl.it](mailto:info@pa-etl.it)



### RB 65 - Adjustable spray wash gun for food industry - 24 bar – 2.4 MPa - Aisi 316

Technical manual: **E 125**

Guns suitable for use up to 24 bar – 2.4 MPa rated pressure pumps.  
 Shockproof gun with adjustable conical jet suitable for corrosive liquids.

DN15



- **30.6300.00** RB65 Aisi 316 G1/2 F
- **30.6310.00** RB65 Aisi 316 w/SWIVEL G1/2 F

- Low pressure gun with conical/pencil jet controlled by the trigger.
- Adjustable screw to vary cone width from 0° to 60°
- Covered by semi-housings of non-stainable shockproof plastic, entirely sealed and with 3 rubber protective rings.
- Plastic trigger protected by hand guard.
- Minimum fatigue for trigger opening and use.
- Internal structure in Sst Aisi 316
- Ergonomic construction
- On request, inlet swivel connection.
- Flow rate 60 l/min max.

#### TECHNICAL SPECIFICATIONS

P/N	FRAME COLOR	PISTON MATERIAL	SEALS MATERIAL	MAX FLOW RATE		RATED PRESSURE		(1) MAX TEMPERATURE CONTINUOUS USE		WEIGHT		INLET
				L/min	USGpm	bar	MPa	°C	°F	g	lbs	
30.6300.00	Blue	SST	Viton	60	15.8	24	2.4	60	140	914	2	G 1/2" F
30.6310.00	Blue	SST	Viton	60	15.8	24	2.4	60	140	1027	2.3	Swivel G 1/2" F

(1) The gun has been designed for continuous use, at a water temperature of 60°C (140°F). It can resist at the max temperature of 90°C (195°F) for short periods only, as, when the gun shuts off, the heater continues to transmit the heat to the water, thus increasing both temperature and pressure up to high, dangerous values.

Using the gun at a water temperature higher than 60°C involves for the operator the use of adequate safety devices, such as gloves, glasses, etc.

**Instruction manual, maintenance, installation, spare parts.**

For a correct utilization, follow the directions of this manual

**Re-print them on the Use and Maintenance booklet of the machine.**

n. 12.9125.00

## DIMENSIONAL DRAWING AND PRESSURE DROP CHART

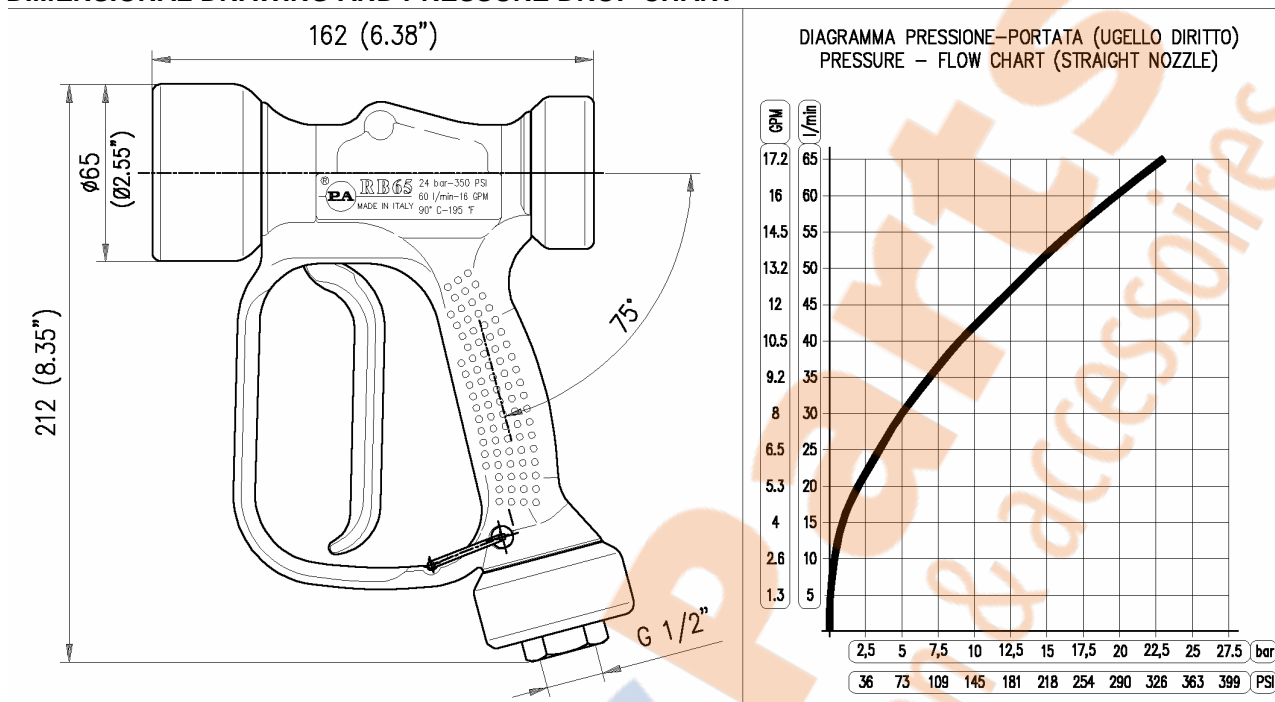

### INSTRUCTIONS

This product is to be utilized with clean fresh water, even slightly additivated with normal detergents. For use involving different or corrosive liquids, contact the PA Technical department. Appropriate filtration should be installed when using unclean liquids. Choose the gun in line with the data of nominal running (system rated pressure, max flow and max temperature). In any case, the pressure of the machine should not exceed the permissible pressure rate imprinted on the gun.

### INSTALLATION

This gun was designed to operate with **hot water** (in compliance with the technical specs). Provide the plant generating **hot water** with an equipment limiting the incidental increase of the fluid temperature.

**Always** fit a safety valve to protect the delivery conduct when the latter is under pressure.

Choose a suitable nozzle and adjust the valve mounted in the front of the gun, thus obtaining a constant supply and avoiding unpleasant pressure spike when closing the system.

If the nozzle wears out, the pressure falls. When you install a new nozzle, adjust the system back to the original pressure.

### OPERATIONS

The gun opens and closes a high pressure conduct by means of a piston acting on a seat; the return is controlled by a spring which releases the trigger.

#### WATER HOSE FEED

By high or very unsteady pressure values on delivery, it is necessary to mount a pressure reducer, both to level the flow rate on delivery and to protect the system components.

## PROBLEMS AND SOLUTIONS

PROBLEMS	PROBABLE CAUSES	SOLUTIONS
Leakage from the nozzle	Presence of impurities Gun seat worn out	Clean Replace seat Fit adequate filters and/or check
Leaking seals	Seals worn out	Replace seal
Difficult trigger opening	High pressure inside circuit	Control the bypass valve and adjust if necessary

Read this manual before starting the assembly.

For a correct utilization, follow the directions described in this manual and re-print them on the Use and maintenance manual of the machine.

The present manual is valid for all the guns named **RB65 Aisi 316**.

### SPARES

Use original PA spares only in order to get both a correct operation and a long lasting, reliable product.

### MAINTENANCE

Maintenance has to be carried out by **Specialized Technicians**.

STANDARD: every 400 working hours (circa 10,000 cycles), check and lubricate the seals with water resistant grease.

SPECIAL: every 800 working hours (circa 20,000 cycles), check the wear of the seals and internal parts and if necessary, replace with original PA parts, taking care during installation to lubricate with water resistant grease.

**CAUTION:** re-assemble the gun restoring the original conditions.

**The manufacturer is not to be considered responsible for damage as a result from incorrect fitting and maintenance.**

*Technical data, descriptions and illustrations are indicative and liable to modification without notice.*

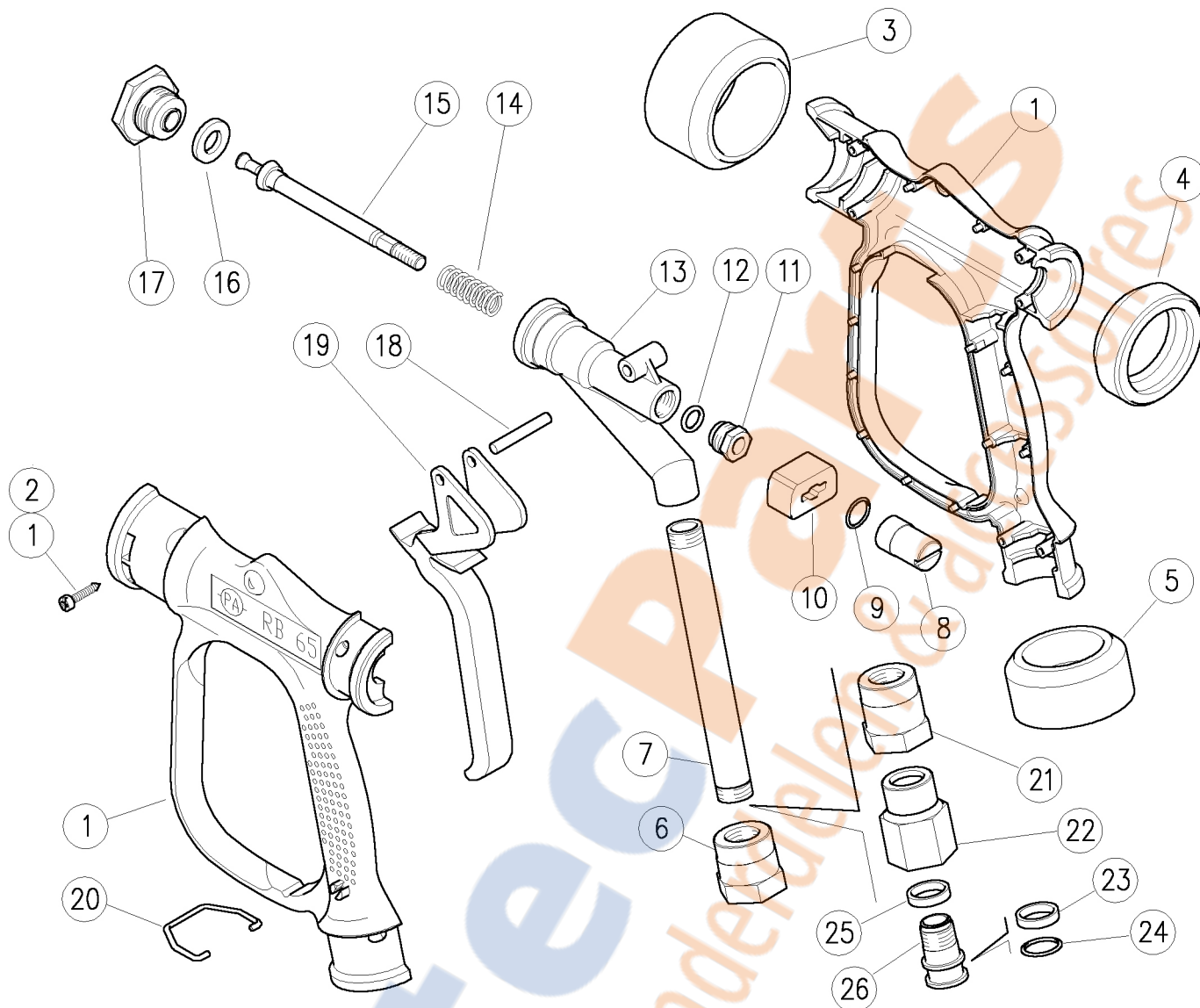

Pos.	P/N	Description	Q.ty	K1	K2	K3	K4	Pos.	P/N	Description	Q.ty	K1	K2	K3	K4
1	30.6420.24	Casing-kit -RB65-60L +screws, Sst.	1					14	30.6410.60	Spring, 1,8x12,8x40 mm aisi316 Sst.	1		•		5
2	16.3075.51	S/tapping screw, DIN7981 3,5x18 mm Sst.	6					15	30.6406.60	Piston -RB65, aisi316 Sst. 60L/min	1		•		5
3	30.6412.84	Front guard ring, TPEs blue	1					16	30.6408.85	Front seal, 11x20,5x3 mm FKM80	1		•	•	10
4	30.6413.84	Back guard ring, TPEs blue	1					17	30.6403.60	Front Coupl. -RB65, aisi316 60L/min	1				3
5	30.6414.84	Lower guard ring, TPEs blue	1					18	30.6428.31	Parallel pin, 5x38 mm brass	1				5
6	30.6407.60	Coupl., M16x1,5F-1/2F Bsp aisi316 Sst. (1)	1					19	30.6301.84	Trigger -RB65, PA grey	1				10
7	30.6409.60	Tube, M16x1,5 FF 136 mm aisi316 Sst.	1					20	30.6415.51	Trigger retainer, Sst.	1				5
8	30.6418.31	Regulating pin, M7	1					21	30.6426.60	Coupl. -SW, M15x1F-M16x1,5F aisi316 (2)	1				2
9	10.3091.10	O-ring, 2x14 mm Vi 70	1		•	•		22	30.6427.60	Coupl. -SW, 1/2F Bsp aisi316 Sst. (2)	1				3
10	30.6302.84	Sliding block, PA grey	1					23	26.1075.85	Bushing, open 15,5x19x4 mm PTFE (2)	1				5
11	30.6417.60	Plug, M14x1 M aisi316 Sst.	1					24	10.3092.10	O-ring, 2x15 mm Vi 70 (2)	1				10
12	10.3170.10	O-ring, 2,62x7,6 mm Vi 70	1		•	•		25	26.1074.85	Bushing, 15,5x19x4 mm PTFE (2)	1				5
13	30.6405.60	Housing -RB65, aisi316 Sst.	1					26	26.1072.60	Pin, M15x1-19 mm Aisi 316 Sst. (2)	1				5
Kit	P/N	Description													
K1	30.6422.24	Seals spares kit -RB65, 3x1pcs.	1												
K2	30.6306.24	Repair kit -RB65- aisi316 Sst., 5x1pcs.	1												

(1) 30.6300.00 (2) 30.6310.00