

SILO CLEANER

The MOSMATIC Silo Cleaner is the perfect cleaning solution for your Silo. This unit is adjustable and can be used in almost any size silo.

In order to use the Silo Cleaner there needs to be a wire harness installed. Please use the hooks that are provided with the Silo Cleaner to balance and stabilize the cleaner.

The MOSMATIC Silo Cleaner is equipped with the MOSMATIC Stabilizer Nozzles making the cleaning power tremendous. The Silo cleaner is made of stainless steel and is virtually maintenance free. The design is compact and user friendly.



Pressure : 275 bar
 Temperature : 120°C
 Throughput medium : ph 3 - 12

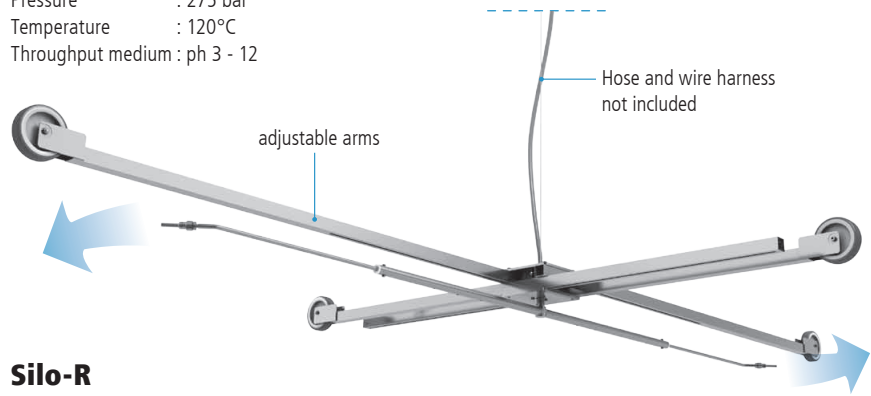

Silo-R

Part No.	Length / Width	Height	IN	Rotor Arm	Nozzles	Wheels	Weight
81.091	2 - 3.5m	210mm	G1/2" F	82.9036	2x 18.050EG	4x ø 100	25kg

MANHOLE CLEANER

Clean ducts and manholes with our MOSMATIC Manhole Cleaner and get cleaning results like never before. The Cleaners are made of stainless steel and therefore rustproof. The Cleaner gets extra protection by a guard plated.

You can choose from different sizes so that you have the best product for your application.

Inlet : G1/2" F
 Pressure : 350 bar
 Temperature : 120°C
 Cage : Stainless Steel
 Nozzles : for 2x 1/8" Nozzles*
 Throughput medium : ph 3 - 12

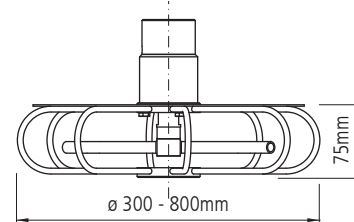

TYR-2f with protective plate

Part No.	ø	Weight
81.033	300	3.7kg
81.043	400	4.4kg
81.053	500	5.3kg
81.063	600	6.4kg
81.083	800	9.5kg



* Nozzles are sold separately.

Important: Do not use unprotected!

ACCESSORIES

for Duct Cleaner on page 38.

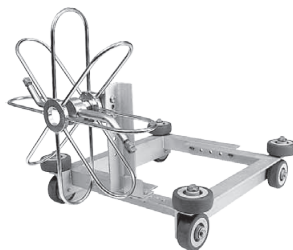

TYR Mobile

Complete stainless steel construction. Height and width adjustable. Can be used with all MOSMATIC duct cleaners in horizontal cleaning.

Part No.	ø (Pipe)	Weight
81.911	150-300	4.1kg
81.902	300-500	4.3kg
81.903	500-600	7.0kg

TYR Hook

For pulling your duct cleaner through long stretches of ducts to stabilize in vertical drops. Quickly attaches to existing cage.



Part No. 81.905